

SCALE 4:1

ALL SOLDER TAIL & FITTING NAIL

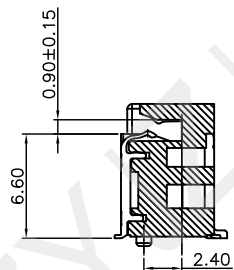

SECTION A-A

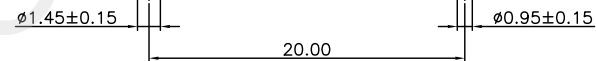
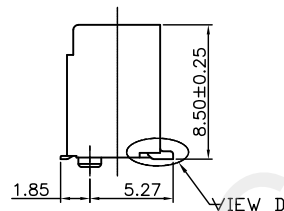
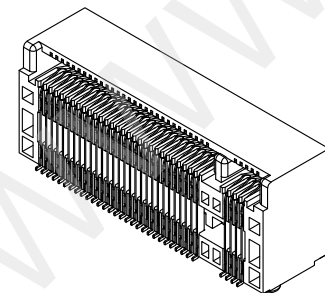
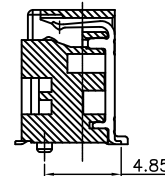

SECTION B-B

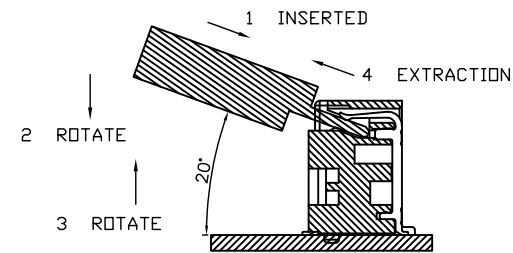

RECOMMENDED OPERATING FLOW:
MATE: 1, 2
UNMATE: 3, 4



深圳市华宇创精密电子有限公司

| | | | |
|---|--------------------|----------------------|-----------------------------------|
| TOLERANCE: X.X ± 0.30 X.XX ± 0.25 X.XXX ± 0.15 X.' $\pm 2'$ X.X' $\pm 0.5'$ | DRAWN BY : 陈一鸣 | DATE : 2014-02-23 | PART NAME: NGFF M.2 8.5H 0.5PH |
| | CHECKED BY: 马跃 | DATE : 2014-02-23 | PART NO. HVC58X-05NGFF-850 |
| UNIT: mm [inch] SCALE:1:1 SIZE: A4 | APPROVED BY: 邱敏 | DATE : 2014-02-23 | DRAW NO: HVC-2506161024 |
| | | | SHEET NO. 1 OF 1 |

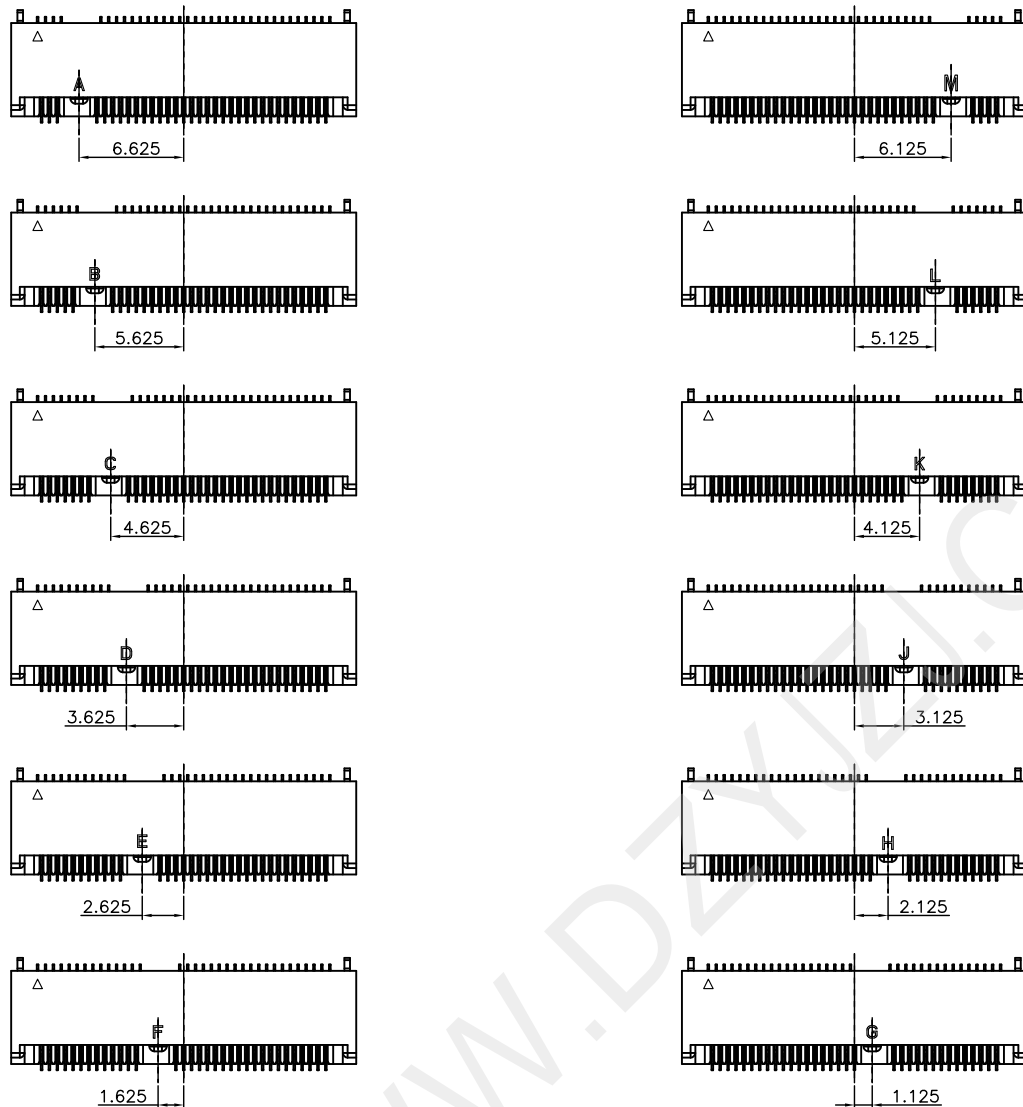

NOTES:

1. MATERIAL :
 - 1.1 HOUSING: THERMOPLASTIC, HIGH TEMPERATURE, UL94 V-0, COLOR: BLACK.
 - 1.2 CONTACT: COPPER ALLOY.
 - 1.3 FITTING NAIL: COPPER ALLOY.
2. FINISH :
 - 2.1 CONTACT
[SEE TABLE] GOLD PLATING ON THE CONTACT AREA.
GOLD FLASH PLATING ON THE SOLDERING AREA.
1.27um~2.54um [50u"~100u"] MIN. NICKEL UNDERPLATING OVERALL.
 - 2.2 FITTING NAIL
2.54um~5.08um [100u"~200u"] MIN. MATTE-TIN PLATING ON THE SOLDERING AREA.
1.27um~2.54um [50u"~100u"] MIN. NICKEL UNDERPLATING OVERALL.

| | | | |
|---|--------------------|----------------------|-------------------------------------|
|  深圳市华宇创精密电子有限公司 | | | |
| TOLERANCE: X.X ±0.30 X.XX ±0.25 X.XXX ±0.15 X' ±2' X.X' ±0.5' | DRAWN BY : 陈一鸣 | DATE : 2014-02-23 | PART NAME: NGFF M.2 8. 5H 0. 5PH |
| | CHECKED BY: 马跃 | DATE : 2014-02-23 | PART NO. HYC58X-05NGFF-850 |
| UNIT: mm [inch] SCALE:1:1 SIZE: A4 | APPROVED BY: 邱敏 | DATE : 2014-02-23 | DRAW NO: HYC-2506161024 |
| | | | SHEET NO. 1 OF 1 |

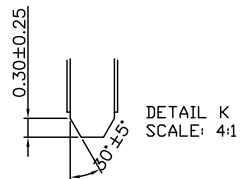
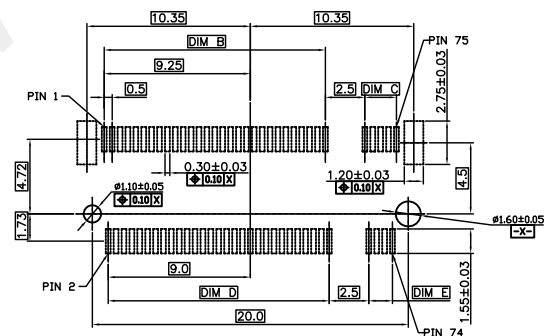
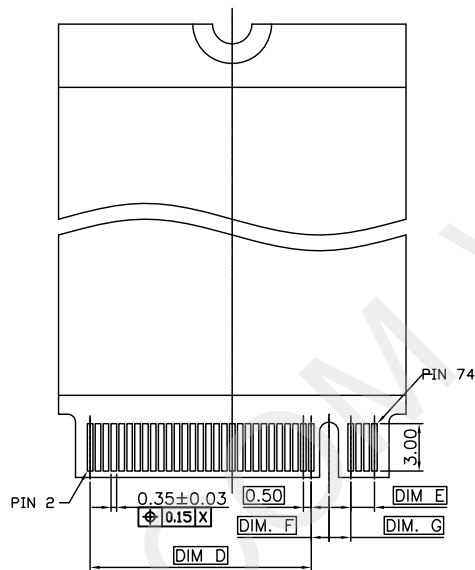
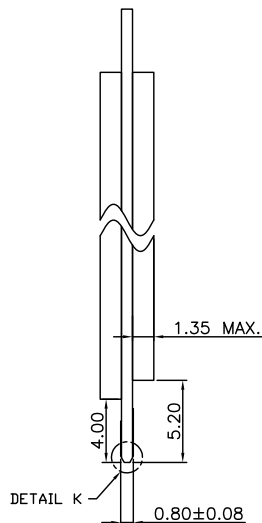
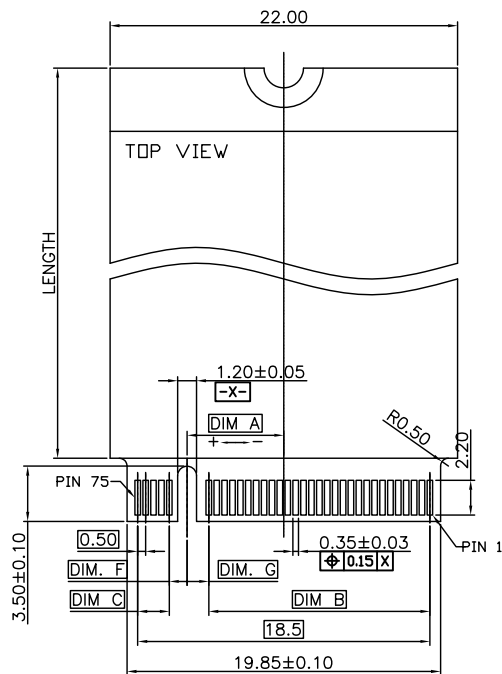

| | | | | | | | |
|--------|--------|--------|--------|--------|--------|--------|--------|
| 1.375 | 1.125 | 1.5 | 14.0 | 2.0 | 14.0 | 6.125 | M |
| 1.375 | 1.125 | 2.5 | 13.0 | 3.0 | 13.0 | 5.125 | L |
| 1.375 | 1.125 | 3.5 | 12.0 | 4.0 | 12.0 | 4.125 | K |
| 1.375 | 1.125 | 4.5 | 11.0 | 5.0 | 11.0 | 3.125 | J |
| 1.375 | 1.125 | 5.5 | 10.0 | 6.0 | 10.0 | 2.125 | H |
| 1.375 | 1.125 | 6.5 | 9.0 | 7.0 | 9.0 | 1.125 | G |
| DIM. G | DIM. F | DIM. E | DIM. D | DIM. C | DIM. B | DIM. A | KEY ID |

| | | | | | | | |
|--------|--------|--------|--------|--------|--------|--------|--------|
| 1.125 | 1.375 | 9.5 | 6.0 | 9.5 | 6.5 | -1.625 | F |
| 1.125 | 1.375 | 10.5 | 5.0 | 10.5 | 5.5 | -2.625 | E |
| 1.125 | 1.375 | 11.5 | 4.0 | 11.5 | 4.5 | -3.625 | D |
| 1.125 | 1.375 | 12.5 | 3.0 | 12.5 | 3.5 | -4.625 | C |
| 1.125 | 1.375 | 13.5 | 2.0 | 13.5 | 2.5 | -5.625 | B |
| 1.125 | 1.375 | 14.5 | 1.0 | 14.5 | 1.5 | -6.625 | A |
| DIM. G | DIM. F | DIM. E | DIM. D | DIM. C | DIM. B | DIM. A | KEY ID |



深圳市华宇创精密电子有限公司

| | | | |
|--|---------------|------------|-----------------------|
| TOLERANCE: X.X ±0.30 X.XX ±0.25 X.XXX ±0.15 X' ±2' X.X' ±0.5' | DRAWN BY : | DATE : | PART NAME: |
| | 陈一鸣 | 2014-02-23 | NGFF M.2 8. 5H 0. 5PH |
| UNIT: mm [inch] SCALE:1:1 SIZE: A4 | CHECKED BY : | DATE : | PART NO. |
| | 马跃 | 2014-02-23 | HVC58X-05NGFF-850 |
| | APPROVED BY : | DATE : | DRAW NO: |
| | 邱敏 | 2014-02-23 | HVC-2506161024 |
| | | | SHEET NO. 1 OF 1 |

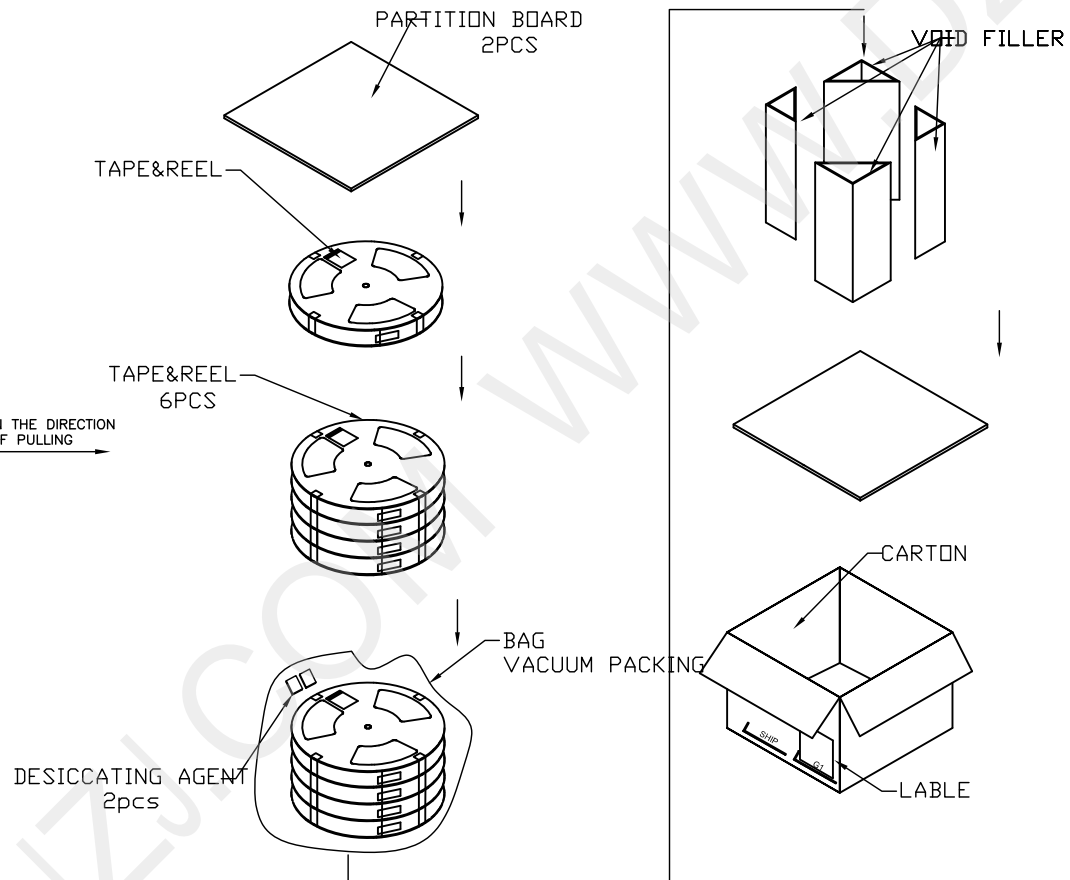
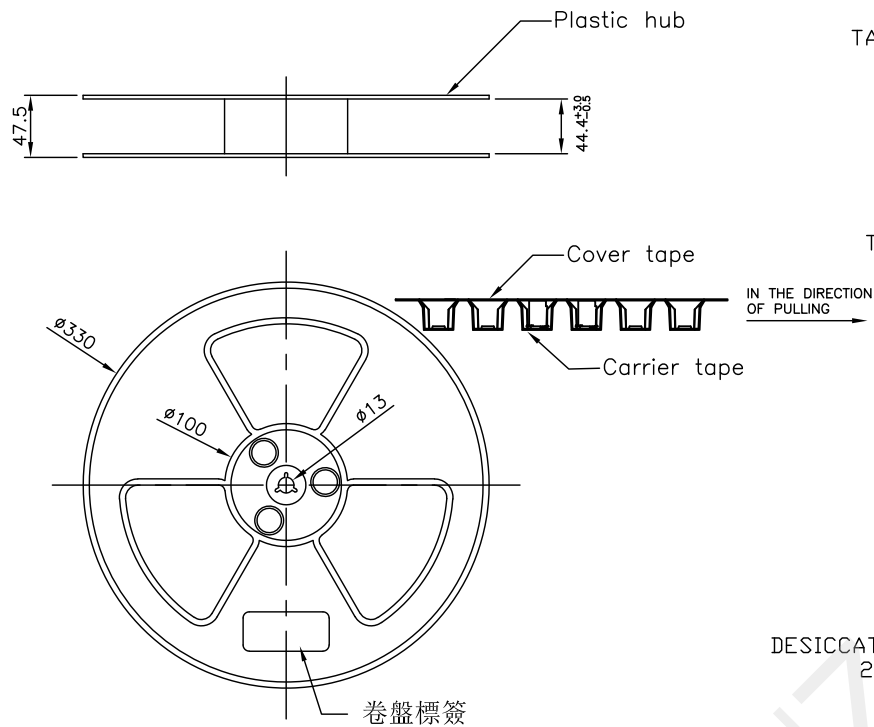

NOTE:

1. REEL MATERIAL : PS; COLOR: BLUE
2. CARRIER MATERIAL : PS; COLOR: TRANSPARENT
3. COVER TAPE MATERIAL : PS; COLOR: TRANSPARENT
4. COVER TAPE REEL STRENGTH : 13"
5. QUANTITY : SEE TABLE
6. Carton : 340(L) * 340(W) * 340(H) mm

| PART NO.. | DIM.H | TYPE | PCS /REEL | REEL /CARTON | CARTON (PCS) |
|-------------------|-------|------|-----------|--------------|--------------|
| HYC58X-05NGFF-850 | 9.60 | 8.5H | 350 | 6 | 2100 |
| HYC57X-05NGFF-670 | 7.80 | 6.7H | 400 | 6 | 2400 |
| HYC56X-05NGFF-550 | 6.60 | 5.5H | 550 | 6 | 3300 |



深圳市华宇创精密电子有限公司

| | | | | |
|--|---------------------------|-----------------------------|--------------------------|----------------------------|
| TOLERANCE: X.X ±0.30 X.XX ±0.25 X.XXX ±0.15 X' ±2' X.X' ±0.5' | DRAWN BY : 陈一鸣 | DATE : 2014-02-23 | PART NAME: 包装图 | |
| | CHECKED BY: 马跃 | DATE : 2014-02-23 | PART NO. | MOLD NO. |
| UNIT: mm [inch] SCALE:1:1 SIZE: A4 | APPROVED BY: 邱敏 | DATE : 2014-02-23 | DRAW NO: | SHEET NO. 1 OF 1 |

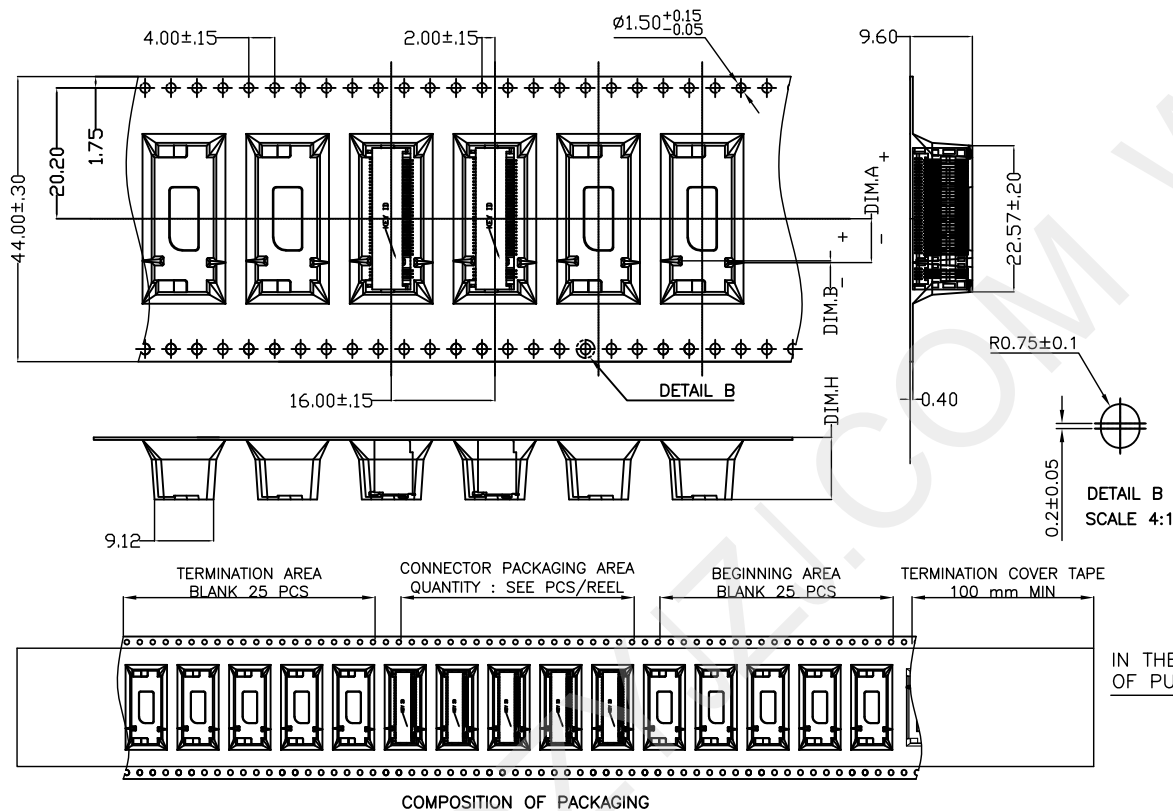



| 2.05 | -1.75 | F |
|--------|--------|--------|
| 0.25 | -2.75 | E |
| 0.25 | -3.75 | D |
| 0.25 | -4.75 | C |
| 0.25 | -5.75 | B |
| 0.25 | -6.75 | A |
| DIM. B | DIM. A | KEY ID |
| -0.25 | 6.25 | M |
| -0.25 | 5.25 | L |
| -0.25 | 4.25 | K |
| -0.25 | 3.25 | J |
| -0.25 | 2.25 | H |
| -0.25 | 1.25 | G |

IN THE DIRECTION OF PULLING

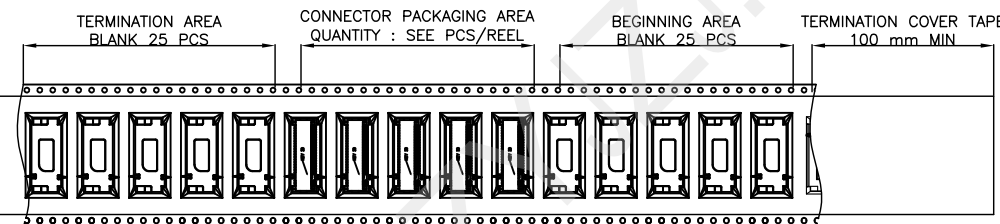
COMPOSITION OF PACKAGING



深圳市华宇创精密电子有限公司

| | | | | |
|---|--------------------|----------------------|-------------------|--------|
| TOLERANCE: X.X ± 0.30 X.XX ± 0.25 X.XXX ± 0.15 X' $\pm 2'$ X.X' $\pm 0.5'$ | DRAWN BY : 陈一鸣 | DATE : 2014-02-23 | PART NAME: 包装图 | |
| | CHECKED BY: 马跃 | DATE : 2014-02-23 | PART NO. | |
|   UNIT: mm [inch] SCALE:1:1 SIZE: A4 | APPROVED BY: 邱敏 | DATE : 2014-02-23 | MOLD NO. | |
| | | | DRAW NO: | |
| | | | SHEET NO. | 1 OF 1 |